

**Instruction Manual
and Experiment Guide
for the PASCO scientific
Model SP-9268**

012-02135E
2/96

STUDENT SPECTROMETER

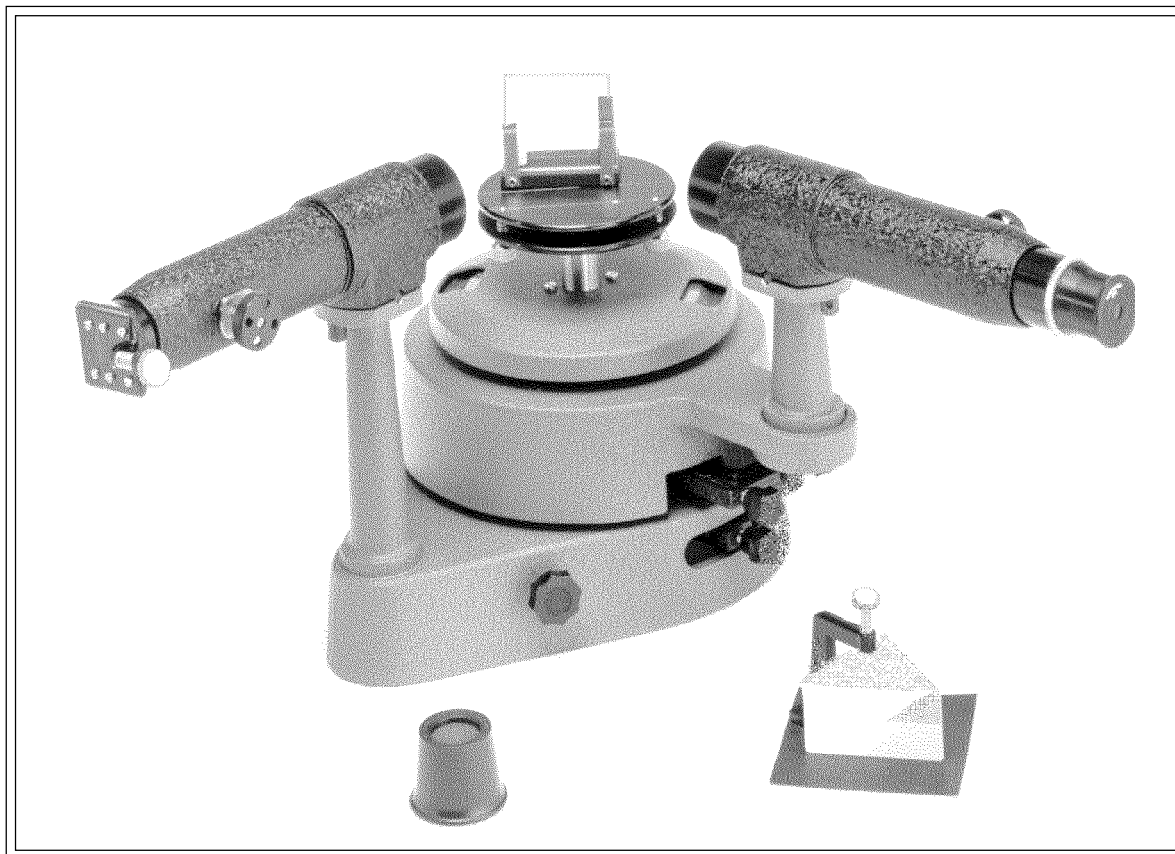

Copyright © January 1991

\$7.50

PASCO®
scientific

10101 Foothills Blvd. • Roseville, CA 95747-7100
Phone (916) 786-3800 • FAX (916) 786-8905 • www.pasco.com

better

ways to

teach science

Table of Contents

| Section | Page |
|---|-------------|
| Equipment Return | ii |
| Introduction | 1 |
| Equipment | 2 |
| Equipment Setup | 3 |
| Measuring Angles of Diffraction | 4 |
| Using the Diffraction Grating | 5 |
| Using the Prism | 6 |
| Maintenance | 8 |
| Appendix: Using the Gaussian Eyepiece | 9 |
| Technical Support | back cover |

Copyright, Warranty and Equipment Return

Please—Feel free to duplicate this manual subject to the copyright restrictions below.

Copyright Notice

The PASCO scientific Model SP-9268 Student Spectrometer manual is copyrighted and all rights reserved. However, permission is granted to non-profit educational institutions for reproduction of any part of this manual providing the reproductions are used only for their laboratories and are not sold for profit. Reproduction under any other circumstances, without the written consent of PASCO scientific, is prohibited.

Limited Warranty

PASCO scientific warrants this product to be free from defects in materials and workmanship for a period of one year from the date of shipment to the customer. PASCO will repair or replace, at its option, any part of the product which is deemed to be defective in material or workmanship. This warranty does not cover damage to the product caused by abuse or improper use. Determination of whether a product failure is the result of a manufacturing defect or improper use by the customer shall be made solely by PASCO scientific. Responsibility for the return of equipment for warranty repair belongs to the customer. Equipment must be properly packed to prevent damage and shipped postage or freight prepaid. (Damage caused by improper packing of the equipment for return shipment will not be covered by the warranty.) Shipping costs for returning the equipment, after repair, will be paid by PASCO scientific.

Credits

This manual edited by: Dave Griffith

Equipment Return

Should the product have to be returned to PASCO scientific for any reason, notify PASCO scientific by letter, phone, or fax BEFORE returning the product. Upon notification, the return authorization and shipping instructions will be promptly issued.

► **NOTE:** NO EQUIPMENT WILL BE ACCEPTED FOR RETURN WITHOUT AN AUTHORIZATION FROM PASCO.

When returning equipment for repair, the units must be packed properly. Carriers will not accept responsibility for damage caused by improper packing. To be certain the unit will not be damaged in shipment, observe the following rules:

- ① The packing carton must be strong enough for the item shipped.
- ② Make certain there are at least two inches of packing material between any point on the apparatus and the inside walls of the carton.
- ③ Make certain that the packing material cannot shift in the box or become compressed, allowing the instrument come in contact with the packing carton.

Address: PASCO scientific
10101 Foothills Blvd.
Roseville, CA 95747-7100

Phone: (916) 786-3800
FAX: (916) 786-3292
email: techsupp@pasco.com
web: www.pasco.com

Introduction

In principle, a spectrometer is the simplest of scientific instruments. Bend a beam of light with a prism or diffraction grating. If the beam is composed of more than one color of light, a spectrum is formed, since the various colors are refracted or diffracted to different angles. Carefully measure the angle to which each color of light is bent. The result is a spectral "fingerprint," which carries a wealth of information about the substance from which the light emanates.

In most cases, substances must be hot if they are to emit light. But a spectrometer can also be used to investigate cold substances. Pass white light, which contains all the colors of the visible spectrum, through a cool gas. The result is an absorption spectrum. All the colors of the visible spectrum are seen, except for certain colors that are absorbed by the gas.

The importance of the spectrometer as a scientific instrument is based on a simple but crucial fact. Light is emitted or absorbed when an electron changes its orbit within an individual atom. Because of this, the spectrometer is a powerful tool for investigating the structure of atoms. It's also a powerful tool for determining which atoms are present in a substance. Chemists use it to determine the constituents of molecules, and astronomers use it to determine the constituents of stars that are millions of light years away.

In its simplest form, a spectrometer is nothing more than a prism and a protractor. However, because of the need for very sensitive detection and precise measurement, a real spectrometer is a bit more complicated. As shown in Figure 1, a spectrometer consists of three basic components; a collimator, a diffracting element, and a telescope.

The light to be analyzed enters the collimator through a narrow slit positioned at the focal point of the collimator lens. The light leaving the collimator is therefore a thin, parallel beam, which ensures that all the light from the slit strikes the diffracting element at the same angle of incidence. This is necessary if a sharp image is to be formed.

The diffracting element bends the beam of light. If the beam is composed of many different colors, each color is diffracted to a different angle.

The telescope can be rotated to collect the diffracted light at very precisely measured angles. With the telescope focused at infinity and positioned at an angle to collect the light of a particular color, a precise image of the collimator slit can be seen. For example, when the telescope is at one angle of rotation, the viewer might see a red image of the slit, at another angle a green image, and so on. By rotating the telescope, the slit images corresponding to each constituent color can be viewed and the angle of diffraction for each image can be measured. If the characteristics of the diffracting element are known, these measured angles can be used to determine the wavelengths that are present in the light.

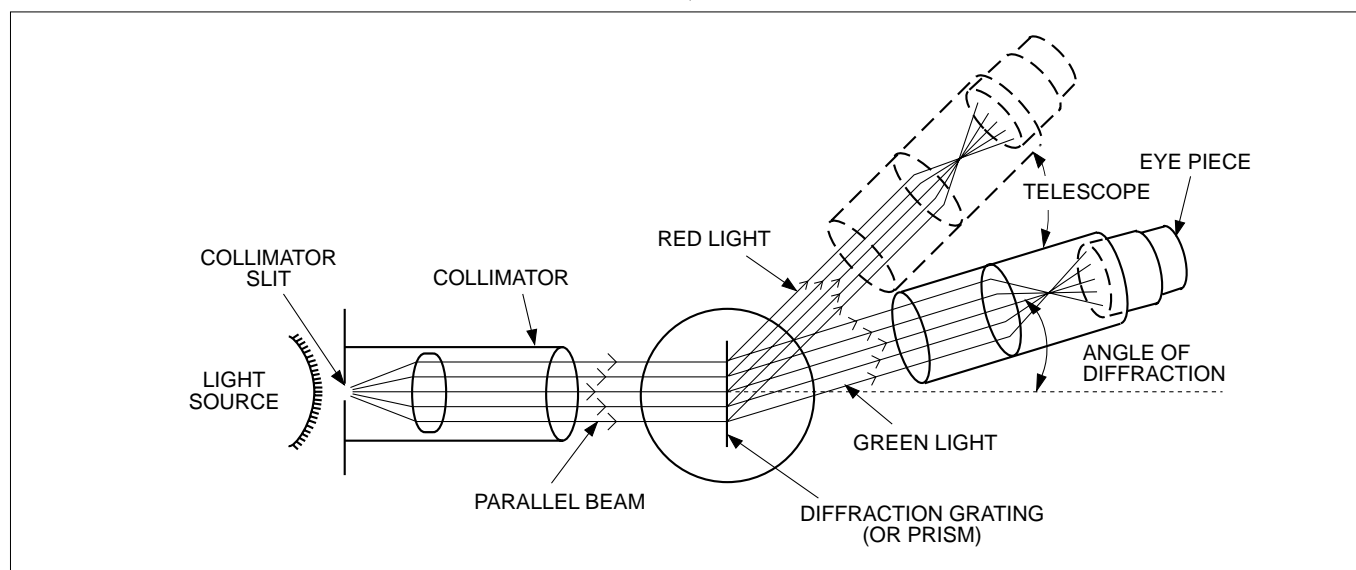

Figure 1 Spectrometer Diagram

Equipment

The PASCO scientific Model SP-9268 Student Spectrometer provides precise spectroscopic measurements using either a prism or a diffraction grating as the diffracting element. The spectrometer includes the following equipment (see Fig 2).

Collimator and Telescope

Both the collimator and the telescope have 178 mm focal length, achromatic objectives, and clear apertures with 32 mm diameters. The telescope has a 15X Ramsden eyepiece with a glass, cross-hair graticule. The collimator is fitted with a 6 mm long slit of adjustable width. Both the collimator and the telescope can be leveled. They can also be realigned (though this is rarely necessary) so that their optical axes are square to the axis of rotation.

Rotating Bases

The telescope and the spectrometer table are mounted on independently rotating bases. Vernier scales provide measurements of the relative positions of these bases to within one minute of arc. The rotation of each base is controlled with a lock-screw and fine adjust knob. With the lock-screw released, the base is easily rotated by hand. With the lock-screw tight, the fine adjust knob can be used for more precise positioning.

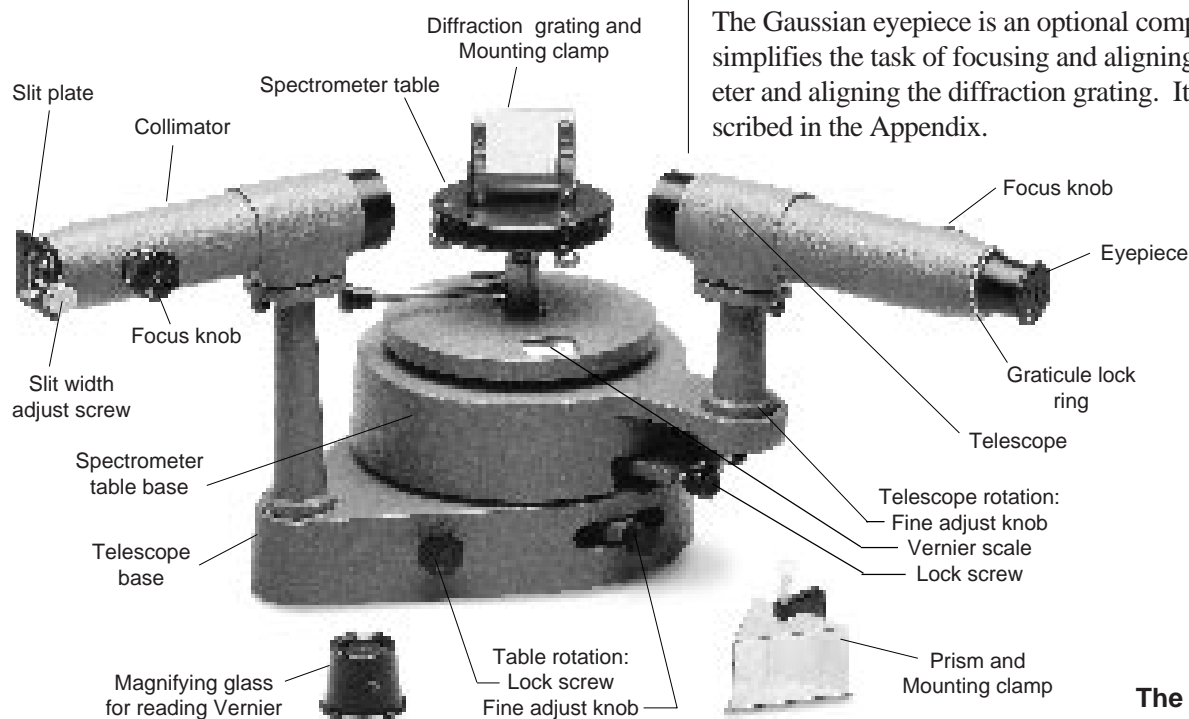

Spectrometer Table

The spectrometer table is fixed to its rotating base with a thumbscrew, so table height is adjustable. Three leveling screws on the underside of the table are used to adjust the optical alignment. (The table must be level with respect to the optical axes of the collimator and telescope if the diffracting element is to retain its alignment for all positions of the telescope.) Thumbscrews are used to attach the prism clamp and the grating mount to the table, and reference lines are etched in the table for easy alignment.

Accessories

Accessories for the spectrometer include a dense flint prism and two mounting clamps; a 300 line/mm diffraction grating and mounting clamp; two thumbscrews for attaching the mounting clamps to the spectrometer table; a magnifying glass for reading the vernier; three allen keys for leveling the telescope and collimator; and a polished hardwood case.

► **NOTE:** A 600 line/mm diffraction grating is available from PASCO as an optional accessory.

Optional Equipment: Gaussian Eyepiece Model SP-9285

The Gaussian eyepiece is an optional component that simplifies the task of focusing and aligning the spectrometer and aligning the diffraction grating. Its use is described in the Appendix.

Figure 2
The Spectrometer

Equipment Setup

► **NOTE:** If you are using the optional Gaussian Eyepiece (SP-9285), equipment setup is somewhat simpler than described below. See the Appendix for instructions.

Leveling the Spectrometer

For accurate results, the diffracting element must be properly aligned with the optical axes of the telescope and collimator. This requires that both the spectrometer and the spectrometer table be level.

- ① Place the spectrometer on a flat surface. If necessary use paper or 3 X 5 cards to shim beneath the wood base until the fixed-base of the spectrometer is level.
- ② Level the spectrometer table by adjusting the three thumbscrews on the underside of the table.

Focusing the Spectrometer

- ① While looking through the telescope, slide the eyepiece in and out until the cross-hairs come into sharp focus. Loosen the graticule lock ring, and rotate the graticule until one of the cross-hairs is vertical. Retighten the lock ring and then refocus if necessary.
- ② Focus the telescope at infinity. This is best accomplished by focusing on a distant object (e.g.: out the window).
- ③ Check that the collimator slit is partially open (use the slit width adjust screw).
- ④ Align the telescope directly opposite the collimator as shown in Figure 3.

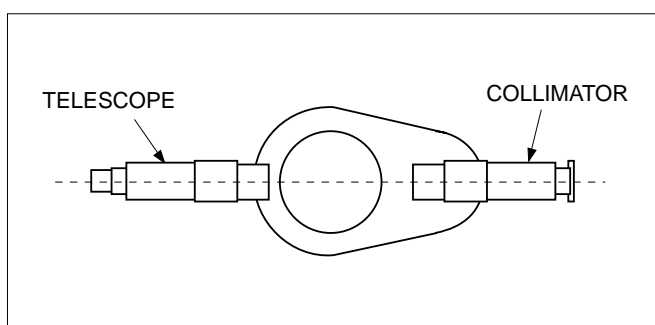

Figure 3 Align the Telescope directly opposite the Collimator

- ⑤ Looking through the telescope, adjust the focus of the collimator and, if necessary, the rotation of the telescope until the slit comes into sharp focus. *Do not change the focus of the telescope.*
- ⑥ Tighten the telescope rotation lock-screw, then use the fine adjust knob to align the vertical line of the graticule with the fixed edge of the slit. If the slit is not vertical, loosen the slit lock ring, realign the slit, and retighten the lock ring. Adjust the slit width for a clear, bright image. Measurements of the diffraction angle are always made with the graticule line aligned along the fixed edge of the slit, so a very narrow slit is not necessarily advantageous.

► **NOTE:** When the telescope and collimator are properly aligned and focused, the slit should be sharply focused in the center of the field of view of the telescope, and one cross-hair should be perpendicular and aligned with the fixed edge of the slit. If proper alignment cannot be achieved with the adjustments just described, you will need to realign the spectrometer as follows.

Realigning the Spectrometer

Under normal circumstances, the spectrometer will maintain its alignment indefinitely. However, if the spectrometer can not be properly focused, as described above, it may be necessary to adjust the optical axes of the collimator and telescope, as follows:

- ① The telescope and collimator pivot about a fulcrum on their respective mounting pillars (See Figure 4). Use the aluminum rod provided with the accessory equipment to adjust the leveling screws. Loosen one as the other is tightened until the unit is level and secure.

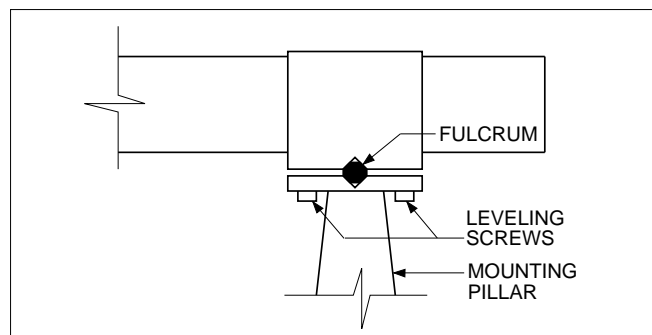

Figure 4 Leveling the Telescope and Collimator

- ② The mounting pillars of the telescope and collimator can be rotated by using an allen wrench to loosen the screws that attach the pillars to their respective bases. To loosen the screw for the collimator, the spectrometer must be removed from the wood base.

To be sure both optical units are square to the axis of rotation, follow the focusing procedure described above, adjusting the mounting pillars as necessary so the slit image is well centered in the viewing field of the telescope.

Measuring Angles of Diffraction

When analyzing a light source, angles of diffraction are measured using the vernier scales. However, the scales only measure the relative rotational positions of the telescope and the spectrometer table base. Therefore, before making a measurement, it's important to establish a vernier reading for the undeflected beam. All angles of diffraction are then made with respect to that initial reading (see Figure 5).

To obtain a vernier reading for the undeflected beam, first align the vertical cross-hair with the fixed edge of the slit image for the undeflected beam. Then read the vernier scale. This is the zero point reading (θ_0).

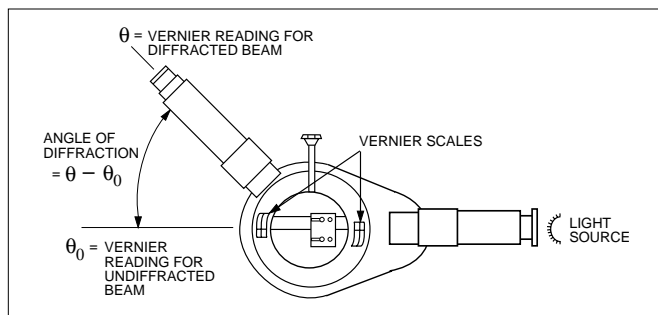

Figure 5 Measuring an Angle of Diffraction

Now rotate the telescope to align the vertical cross-hair with the fixed edge of a deflected image. Read the vernier scale again. If this second reading is θ , then the actual angle of diffraction is $\theta - \theta_0$. If the table base is rotated for some reason, the zero point changes, and must be remeasured.

Reading the Vernier Scales

To read the angle, first find where the zero point of the vernier scale aligns with the degree plate and record the value. If the zero point is between two lines, use the smaller value. In Figure 6, below, the zero point on the vernier scale is between the 155° and $155^\circ 30'$ marks on the degree plate, so the recorded value is 155° .



Now use the magnifying glass to find the line on the vernier scale that aligns most closely with any line on the degree scale. In the figure, this is the line corresponding to a measurement of 15 minutes of arc. Add this value to the reading recorded above to get the correct measurement to within 1 minute of arc: that is, $155^\circ + 15' = 155^\circ 15'$.

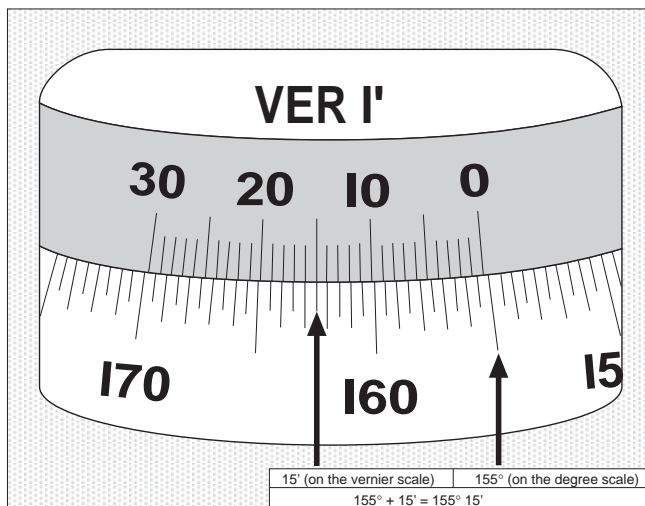

Figure 6 Reading the Vernier Scales

Using the Diffraction Grating

► **IMPORTANT:** The Diffraction Grating is a delicate component. Be careful not to scratch the surface and always replace it in the protective foam wrapping when it is not being used.

Aligning the Grating

To accurately calculate wavelengths on the basis of diffraction angles, the grating must be perpendicular to the beam of light from the collimator.

- Align and focus the spectrometer as described earlier. The telescope must be directly opposite the collimator with the slit in sharp focus and aligned with the vertical cross-hair.

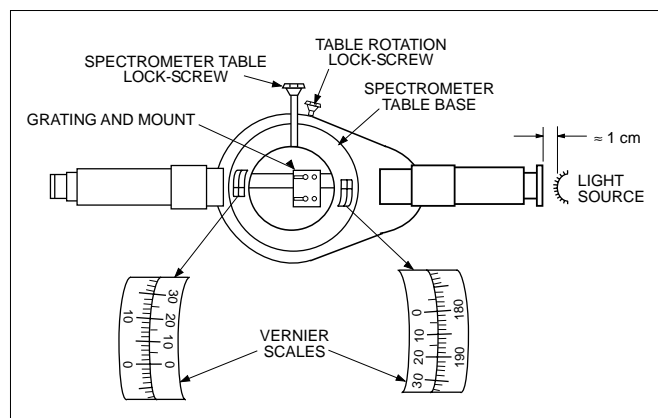

Figure 7

Perform steps 2-5 with reference to Figure 7.

- Loosen the spectrometer table lock-screw. Align the engraved line on the spectrometer table so that it is, as nearly as possible, colinear with the optical axes of the telescope and the collimator. Tighten the lock-screw.
- Using the thumbscrews, attach the grating mount so it is perpendicular to the engraved lines.
- Insert the diffraction grating into the clips of the mount. To check the orientation of the grating, look through the grating at a light source and notice how the grating disperses the light into its various color components. When placed in the grating mount, the grating should spread the colors of the incident light horizontally, so rotation of the telescope will allow you to see the different colored images of the slit.

- Place a light source (preferably one with a discrete spectrum, such as a mercury or sodium lamp) approximately one centimeter from the slit. Adjust the slit width so the slit image is bright and sharp. If necessary, adjust the height of the spectrometer table so the slit image is centered in the field of view of the telescope.

► **IMPORTANT:** Stray light can obscure the images. Use the spectrometer in a semi-darkened room or drape a sheet of opaque material over the spectrometer.

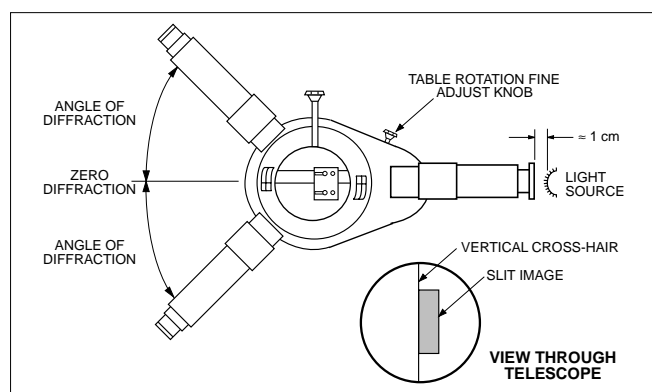

Figure 8

Perform steps 6-9 with reference to Figure 8.

- Rotate the telescope to find a bright slit image. Align the vertical cross-hair with the fixed edge of the image and carefully measure the angle of diffraction. (See the previous section, *Measuring Angles of Diffraction*.)
- The diffraction grating diffracts the incident light into identical spectra on either side of the line of the undiffracted beam. Rotate the telescope back, past the zero diffraction angle, to find the corresponding slit image. Measure the angle of diffraction for this image.
- If the grating is perfectly aligned, the diffraction angles for corresponding slit images will be identical. If not, use the table rotation fine adjust knob to compensate for the difference (i.e.; to align the grating perpendicular to the collimator beam so the two angles will be equal).

- ⑨ Repeat steps 6-8 until the angles for the corresponding slit images are the same to within one minute of arc.

Making the Reading

Once the grating is aligned, do not rotate the rotating table or its base again. Diffraction angles are measured as described in the previous section, *Measuring Angles of Diffraction*. (Since the vernier scales were moved when the spectrometer table was adjusted, the point of zero diffraction must be remeasured).

Wavelengths are determined according to the formula:

$$\lambda = \frac{a \sin \theta}{n}$$

where λ is the wavelength; a is the distance between lines on the diffraction grating

($a = 3.3 \times 10^{-3}$ mm for the 300 line/mm grating or 1.66×10^{-3} mm for the optional 600 line/mm grating);

θ is the angle of diffraction; and n is the order of the diffraction spectrum under observation.

Using the Prism

Advantages and Disadvantages

A prism can also be used as the diffracting element in a spectrometer since the index of refraction of the prism (and therefore the angle of refraction of the light) varies slightly depending on the wavelength of the light.

A prism refracts the light into a single spectrum, whereas the grating divides the available light into several spectra. Because of this, slit images formed using a prism are generally brighter than those formed using a grating. Spectral lines that are too dim to be seen with a grating can often be seen using a prism.

Unfortunately, the increased brightness of the spectral lines is offset by a decreased resolution, since the prism doesn't separate the different lines as effectively as the grating. However, the brighter lines allow a narrow slit width to be used, which partially compensates for the reduced resolution.

With a prism, the angle of refraction is not directly proportional to the wavelength of the light. Therefore, to measure wavelengths using a prism, a graph of wavelength versus angle of refraction must be constructed using a light source with a known spectrum. The wavelength of unknown spectral lines can then be interpolated from the graph.

Once a calibration graph is created for the prism, future wavelength determinations are valid only if they are made with the prism aligned precisely as it was when the graph was produced. To ensure that this alignment can be reproduced, all measurements are made with the prism aligned so that the light is refracted at the angle of minimum deviation.

The Angle of Minimum Deviation

The angle of deviation for light traversing a prism is shown in Figure 9. For a given wavelength of light traversing a given prism, there is a characteristic angle of incidence for which the angle of deviation is a minimum. This angle depends only on the index of refraction of the prism and the angle (labeled A in Figure 8) between the two sides of the prism traversed by the light. The relationship between these variables is given by the equation:

$$n = \frac{\sin \left\{ \frac{A+D}{2} \right\}}{\sin \frac{A}{2}}$$

where n is the index of refraction of the prism; A is the angle between the sides of the prism traversed by the light; and D is the angle of minimum deviation. Since n varies with wavelength, the angle of minimum deviation also varies, but it is constant for any particular wavelength.

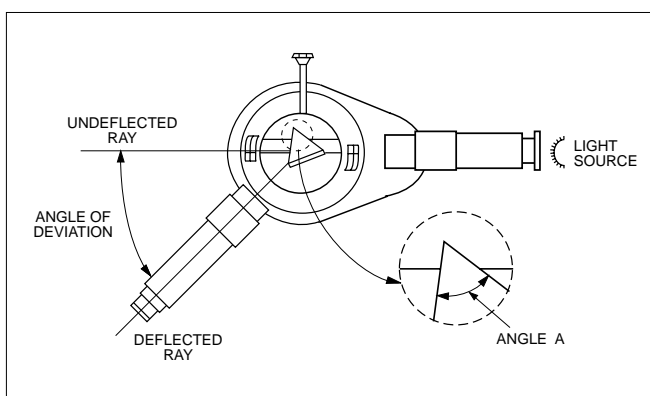

Figure 9 Angle of Deviation

To Measure the Angle of Minimum Deviation:

- ① Align and focus the spectrometer as described earlier.
- ② Use the two thumbscrews to attach the prism clamp to the spectrometer table and clamp the prism in place as shown in Figure 10.
- ③ Place the light source a few centimeters behind the slit of the collimator. (It may be helpful to partially darken the room, but when using the prism this is often not necessary.)

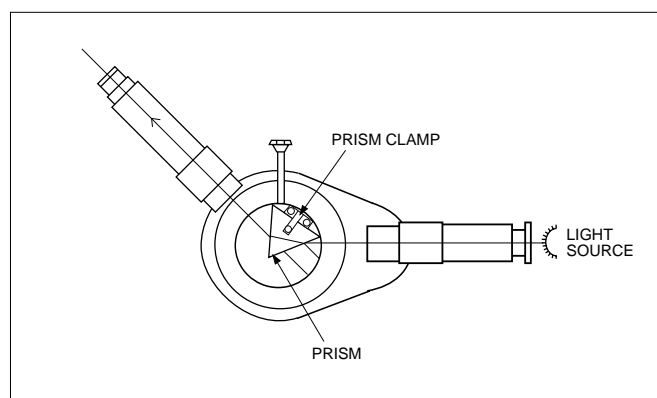

Figure 10 Mounting the Prism

- ④ With the prism, it is generally possible to see the refracted light with the naked eye. Locate the general direction to which the light is refracted, then align the telescope and spectrometer table base so the slit image can be viewed through the telescope.
- ④ While looking through the telescope, rotate the spectrometer table slightly back and forth. Notice that the angle of refraction for the spectral line under observation changes. Rotate the spectrometer table until this angle is a minimum, then rotate the telescope to align the vertical cross-hair with the fixed edge of the slit image. Use the fine adjust knobs to make these adjustments as precisely as possible, then measure the telescope angle using the vernier scale.
- ⑥ Without changing the rotation of the spectrometer table, remove the prism and rotate the telescope to align the cross-hair with the fixed edge of the undiffracted beam. Measure the angle on the vernier scale. The difference between this angle and that recorded for the diffracted spectral line in step 5, is the angle of minimum deviation. Notice that, since the determination of the angle of minimum deviation for each spectral line requires rotational adjustments of the spectrometer table, the angle of the undeflected beam must be remeasured for each line.

Maintenance

Periodically clean the telescope aperture, the collimator aperture, and the prism with a nonabrasive lens paper (available at any camera store). No other regular maintenance is required.

► **IMPORTANT:** Always handle the spectrometer and its accessories with care to avoid scratching the optical surfaces and throwing off the alignment. Also, when not in use, the spectrometer should be stored in its hardwood case.

Appendix: Using the Gaussian Eyepiece

The optional Gaussian eyepiece (Model SP-9285) simplifies the task of aligning and focusing the spectrometer and aligning the diffraction grating. One Gaussian eyepiece can be used to align and focus any number of spectrometers, so only one is generally needed per lab.

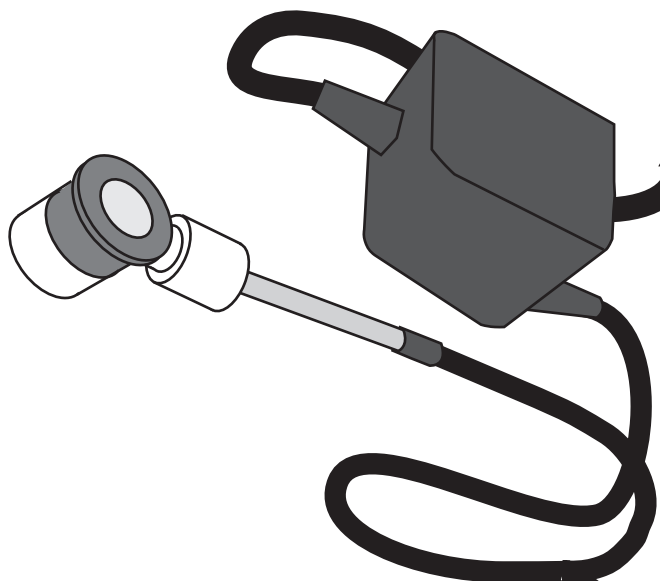

To Align and Focus the Spectrometer Using the Gaussian Eyepiece:

- ① Remove the telescope eyepiece and replace it with the Gaussian eyepiece.
 - ② While looking through the telescope, slide the eyepiece in and out until the cross-hairs come into sharp focus. Loosen the graticule lock ring, and rotate the graticule until one of the cross-hairs is vertical. Retighten the lock ring and then refocus if necessary.
 - ③ Plug in the power supply of the Gaussian eyepiece. The light from the eyepiece is reflected along the optical axis of the telescope by a half-silvered mirror. Looking through the eyepiece, you'll see the cross-hairs lighted up as they scatter some of the light back into the eyepiece.
 - ④ Mount the grating holder to the spectrometer table and insert the diffraction grating.
 - ⑤ Looking through the telescope, rotate the table until a patch of light is reflected back through the telescope from the glass surfaces of the grating. The spectrometer table and the telescope must be at least roughly level to achieve this reflection. If they are not, see *Realigning the Spectrometer*, earlier in the manual.
 - ⑥ Adjust the focus of the telescope until the cross-hairs and their reflected images are in sharp focus. The glass slides of the grating are not efficient reflectors, so you must look carefully to see them.
- **IMPORTANT:** The grating is sandwiched between two glass slides so, depending on how parallel the slides are, you may see as many as four reflected images of the cross-hairs. In the following steps, you will be instructed to superimpose the graticule with its reflected image. If there is more than one image, just center the cross-hairs as accurately as possible between the images.
- ⑦ Use the table rotation fine adjust knob to align the vertical cross-hair with its reflected image.
 - ⑧ Adjust the spectrometer table leveling screws until the cross-hairs are superimposed on the reflected image.
 - ⑨ Rotate the spectrometer table 180° and, using the table rotation fine adjust knob, align the vertical cross-hair with the reflected image.
 - ⑩ Adjust the table leveling screws to remove half the separation between the horizontal cross-hair and the reflected image. Adjust the telescope leveling screws to remove the remaining error, so the cross-hairs and their reflected images are superimposed.
 - ⑪ Repeat steps 9 and 10 until the cross-hairs and their reflected images are superimposed from both sides of the diffraction grating.
 - ⑫ Unplug the Gaussian eyepiece. Adjust the slit of the collimator so it is open and vertical.

- ⑬ Illuminate the slit with an external light source. Rotate the telescope directly opposite the collimator and focus the collimator only (do not disturb the telescope focus) until the illuminated slit is in sharp focus. If the collimator slit is not vertical, loosen the lock ring, align the slit vertically, and then retighten the lock ring. Then align the fixed edge of the slit with the vertical cross-hair.
- ⑭ Adjust the collimator leveling screws until the slit is vertically centered in the field of view of the telescope. (As with the telescope, you may need to adjust the collimator so that its optical axis is square to the axis of rotation.) The telescope, collimator, and spectrometer table are now properly aligned.
- ⑮ If you are going to use the grating, plug the Gaussian eyepiece back in and rotate the spectrometer table until the vertical cross-hair is again aligned with its reflected image. This insures that the grating is perpendicular to the optical axis of the spectrometer.

- ⑯ If you wish, you may replace the Gaussian eyepiece with the original eyepiece. The focus of the telescope will be maintained if you slide in the original eyepiece until the cross-hairs are in sharp focus.

Alignment Error

The multiple reflections from the glass slides of the grating introduce some error into the alignment procedure. Normally, centering the cross-hairs between the reflected images will reduce the error below the 1-minute resolution that is obtainable when reading the vernier scales.

To verify the alignment, use a light source with discrete spectral lines such as a sodium or mercury vapor lamp. If the alignment is correct, corresponding spectral lines on opposite sides of the optical axis will have equal angles of diffraction. If necessary, adjust the rotation of the spectrometer table until the measurements are the same.

Technical Support

Feed-Back

If you have any comments about this product or this manual please let us know. If you have any suggestions on alternate experiments or find a problem in the manual please tell us. PASCO appreciates any customer feedback. Your input helps us evaluate and improve our product.

To Reach PASCO

For Technical Support call us at 1-800-772-8700 (toll-free within the U.S.) or (916) 786-3800.

email: techsupp@PASCO.com

Tech support fax: (916) 786-3292

WEB: <http://www.pasco.com>

Contacting Technical Support

Before you call the PASCO Technical Support staff it would be helpful to prepare the following information:

- If your problem is with the PASCO apparatus, note:
Title and Model number (usually listed on the label).

Approximate age of apparatus.

A detailed description of the problem/sequence of events. (In case you can't call PASCO right away, you won't lose valuable data.)

If possible, have the apparatus within reach when calling. This makes descriptions of individual parts much easier.

- If your problem relates to the instruction manual, note:
Part number and Revision (listed by month and year on the front cover).

Have the manual at hand to discuss your questions.

